



Racking

Creating Space

PALLET RACKING



Designed and manufactured to suit your storage requirements

RADIUS
OFFICE

info@radiusoffice.com
www.radiusofficefurniture.com

 **STORAGRID**

PALLET RACKING



Adjustable Pallet Racking System



Adjustable Pallet Racking System



Narrow Aisle Racking System

Totally Versatile Pallet Racking

Storagrid Metal Products continue to push forward in both quality and customer satisfaction and have a wide range of storage solutions to suit any application.

Storagrid's pallet racking has been a forerunner for many years and as competition increases, so has Storagrid's attitude to be consistently at the top of the pack.

At Storagrid Metal Products, we provide you, the customer, with a system tailored specially for your requirements. Each job is manufactured specifically for you and can be any height or length. Our design department will liaise with you in order to provide the best possible layout design for your needs and advise on maximising space utilisation and minimising costs.

“Adjustable Pallet Racking is probably the most widely used system for storing pallets”

PALLET RACKING

Pallet Racking Technical Specification

Beam Sections

Storagrid offer a wide range of beams to provide the most cost-effective solution for any storage requirement. Beams are available as open or boxed sections to cater for any load capacity even up to 7200kg per pair. Beams are roll-formed from high-quality steel and depending on beam type have either one or two sections. These sections are welded to the anchor plates and then powder coated. Our experienced sales team will recommend the most suitable beam for your requirements.

Uprights

Uprights are available in widths of 80, 100, and 120mm to give bay loads of up to 25 tonnes. Should bay loads in excess of this figure be required, please contact our sales force for free professional advice. Each upright is roll-formed from high-quality steel before being powder coated. Our unique slot pattern has been specifically designed to generate a 'wedge' effect when the beam is located into the upright. This creates a very rigid racking structure as the lug pulls the anchor plate hard against the upright. The upright pitch is 50mm; this gives close beam adjustment and ensures that no space is wasted. Uprights can be made up to 7500mm in one piece, eliminating the need for splicing up to that point. After this point, uprights can be spliced using our robust splice to cater for any height requirement.

Load capacity determined by most critical value of 1/200 deflection limit or safety factor =2
All load capacities are for Uniformly Distributed Load (UDL)

Beam Loads Open

CLEAR ENTRY (mm)	60 x 1.7 BEAM (kg)	87 x 1.7 BEAM (kg)	101 x 1.7 BEAM (kg)	101 x 2.25 BEAM (kg)
1350	1705	2852	3592	4476
1500	1428	2612	3287	4087
1800	1063	2247	2824	3498
2025	867	1831	2564	3167
2250	729	1525	2193	2676
2400	656	1364	1960	2386
2700	541	1114	1598	1939
3000	456	930	1333	1612

Beam Loads Boxed

CLEAR ENTRY (mm)	86 x 1.7 BEAM (kg)	95 x 1.7 BEAM (kg)	103 x 1.7 BEAM (kg)	123 x 1.7 BEAM (kg)	146 x 1.8 BEAM (kg)
1350	5443	7033	7258	7258	7258
1500	5443	6406	7012	7258	7258
1800	4155	5366	5957	7258	7258
2025	3414	4329	5088	6634	7258
2250	2847	3574	4192	5645	6830
2400	2534	3180	3725	5071	6126
2700	2050	2572	3004	4179	5033
3000	1687	2129	2480	3522	4231
3300	1433	1796	2088	3020	3622
3600	1228	1540	1785	2574	3149
3900	1067	1337	1547	2224	2772

PALLET RACKING

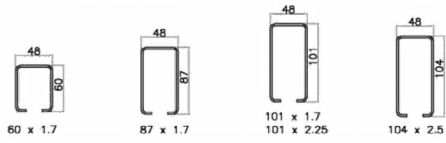

Open Beam Type

Frame Assembly

Storagrid offer welded or bolted frame assembly depending on your requirements. Welded frames are factory welded before being powder coated. Bolted frames can be supplied factory assembled or supplied in component form for economical shipping and fast, easy assembly on site. Our experienced sales team will be able to recommend the ideal upright and frame for your specific needs.

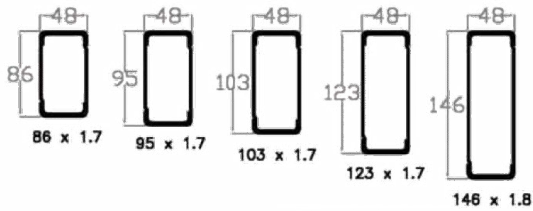

Boxed Beam Type

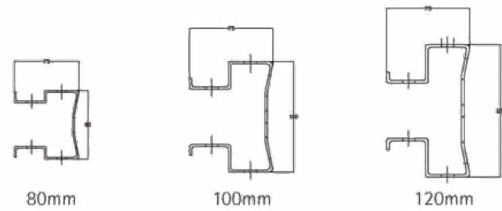

Profile

- Medium Duty 80mm
- Heavy Duty 100mm
- Extra Heavy Duty 120mm

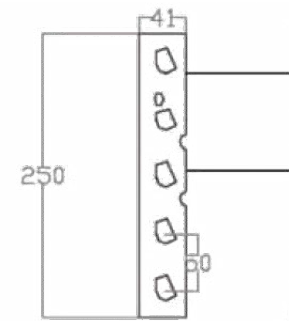
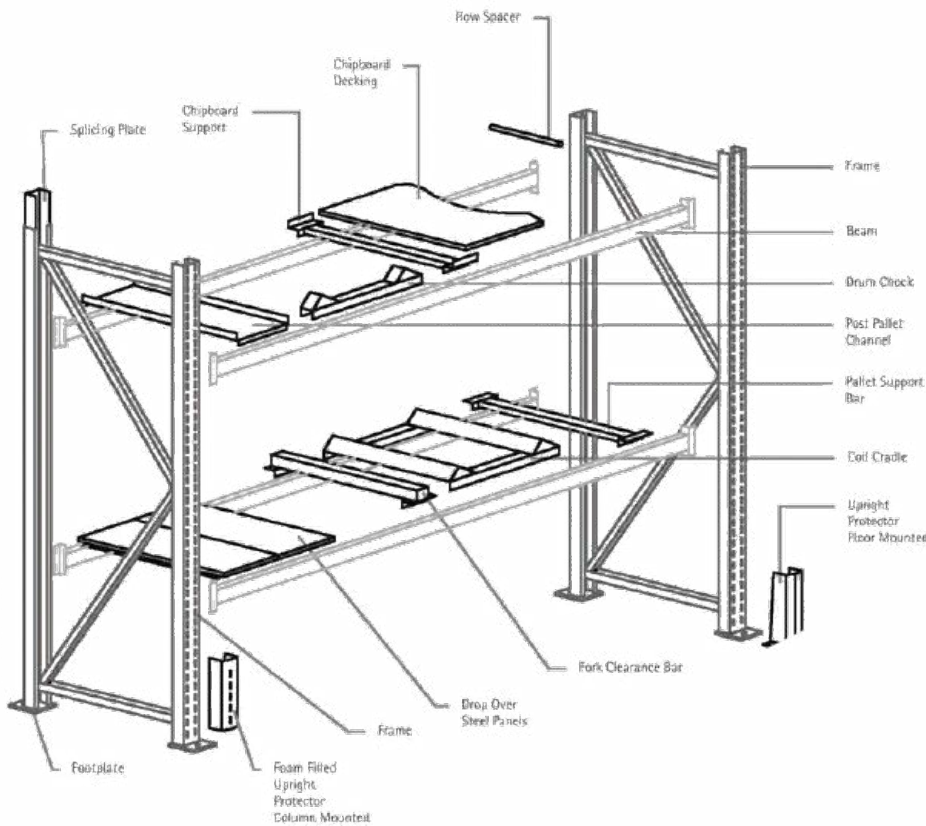

5 Lugged Anchor Plate for strength and durability

Standard Adjustable Pallet Racking

DRIVE-IN RACKING

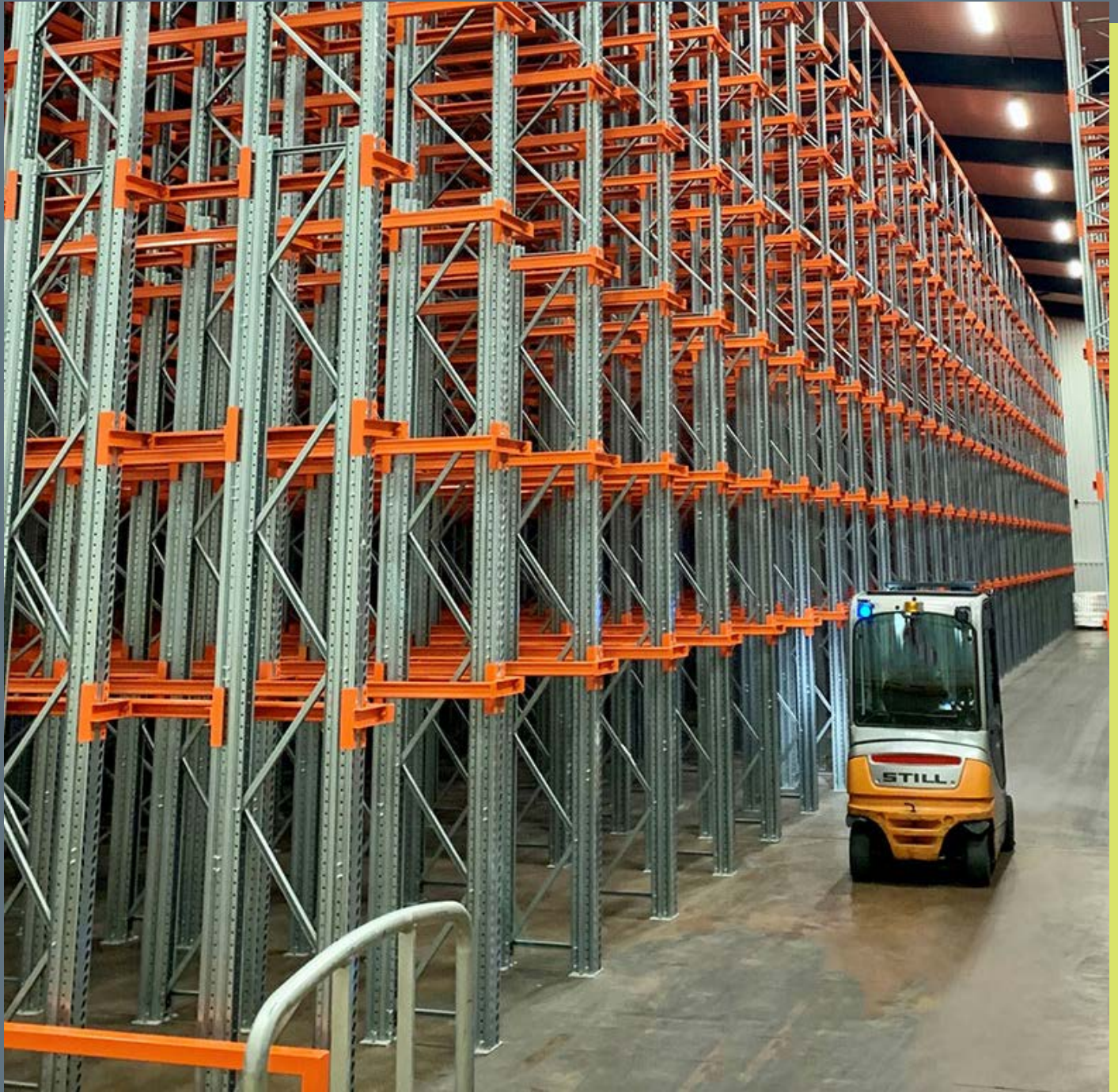

Designed and manufactured to suit your storage requirements

DRIVE-IN RACKING



Typical Drive-in Racking Installation



Drive-in & Drive-Through Racking

Storagrid's Drive-in / Drive-through Racking provides an ideal storage system for crushable goods that cannot be block stacked or for pallets with predictable stock movements, as stock rotation is operated on a 'first in last out' basis.

This system provides a high degree of space utilisation with the racking in a continuous block not divided by aisles. The reduction of space allocated to aisles results in a cost-effective, high density, bulk storage system.

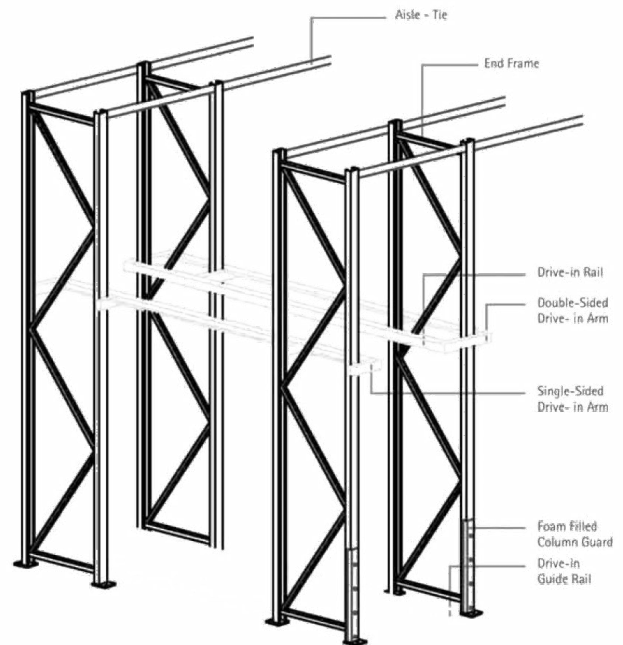

Technical Illustration

Fork lift trucks drive into the installation to pick or drop pallets which are stored one behind the other on specially designed cantilever rails. Storagrid's column protectors and/or guide rails could be incorporated into the system to provide extra protection against forklift damage.

SPECIALIST

With experience gained from nearly 50 years in manufacturing storage systems, Storagrid have a solution for every storage requirement.

In addition to regular Pallet Racking and Drive-in systems, we also offer storage solutions for more specialist areas.



Tyre Racking

Tyre racking is an efficient storage system for maximising storage capacity of tyres. Our proven design system and manufacturing flexibility ensures that each system is designed to suit your needs. To maximise storage and reduce wasted space, tiered systems complete with pedestrian walkways are often employed to fully utilise building height.



Carpet Racking

Storing carpet on racking minimises product handling and therefore reduces the risk of damage when compared to stacking the material on the ground. It also simplifies stock control by making the product highly visible.



Cable Racking

Cable racking is the ideal solution for storing cable reels. Storing the reels horizontally on racking maximises the use of storage space and also provides for easy stock identification. In addition, by mounting each drum on an axle, the cable can be reeled or unreeling while still located in the rack. As a manufacturer, we design the system to suit your exact needs and drum requirement.

SPECIALIST



Mobile Racking

Mobile racking is a cost-effective method of increasing storage space. By mounting the racking on mobile bases, the number of aisles can be significantly reduced when compared against conventional warehouse rack/aisle layouts. This system is ideal for high-density storage and can increase effective storage space by up to 80%.



Live Storage

Storagrid Live Storage is the perfect system for storing goods that need to be retrieved on a first in, first out basis. The system is loaded on one side and unloaded on the other. A series of gravity rollers convey the goods from the load side to the offload side, giving first in, first out pallet handling.



Exhaust Racking

Exhaust racking is an ideal solution for storing this uniquely shaped product by hanging it or positioning it upright. As it creates a neat and tidy storage system, it makes stock control simple.



Archive Storage Racking

Archive racking is used for high-density archive box storage. We design the system to suit your exact requirements to maximise the number of boxes that can be stored and ensure all your storage space is efficiently used. In this type of installation, the building height is used by creating a number of tiers complete with pedestrian walkways. Although two and three tiers are typical, Storagrid have completed installations that are five tiers high.

CANTILEVER RACKING

Cantilever Racking

Storagrid cantilever racking is suitable for the storage of long products and is a robust design to cope with arduous environments. Cantilever racking can be used indoors (painted) or outdoors (galvanised). We can incorporate a canopy roof and complete roof structures.

- Rounded ends on arms and bases to protect goods, fork trucks, and pedestrians.
- Unique clip arm requires no tools or bolts for adjusting arms
- Arms are adjustable at 100mm pitches
- Arms move upwards and sideways, eliminating damage to columns if struck accidentally
- All components are powder coated paint for a tough durable finish or galvanised for outdoor use.

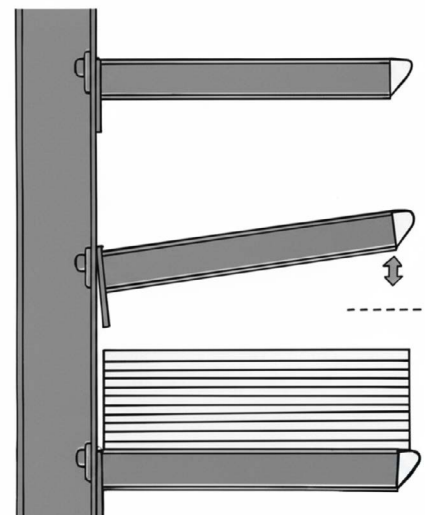
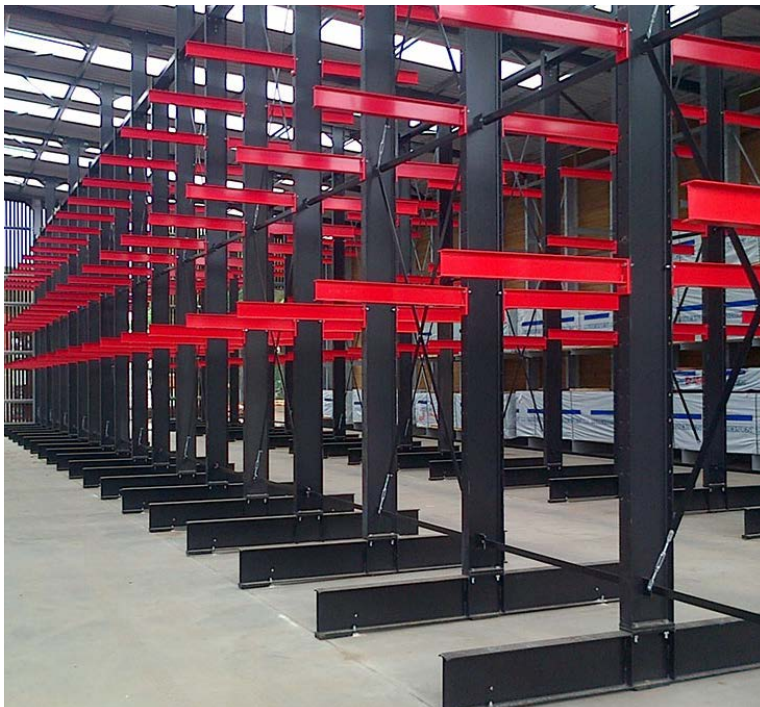

Movable Arm Illustration

ACCESSORIES



Floor Mounted Column Guards

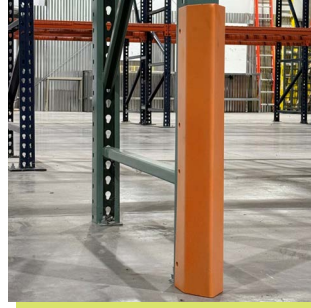

Foam Filled Column Protectors

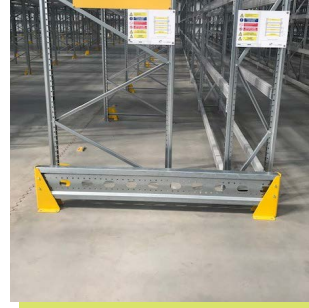

Crash Barriers



Drop Over Panels



Slatted Timber Panels



Chipboard Panels



Pallet Support Bars



Post Pallet Channels



Fork Clearance Bars



Chipboard Support Bars



Back Stop Beams



Drum Chocks



Coil Cradles



Guide Rails

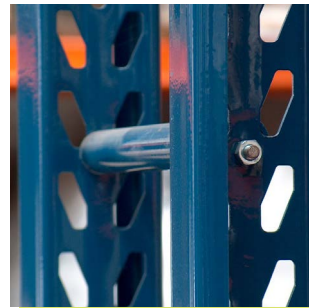

Row Spacers

Colour Range

All products are powder coated to give a high quality, tough, and durable finish. Standard end frame colours are Blue RAL5001 or Grey RAL7011, while beams and accessories are Orange RAL2004. However, our state-of-the-art painting facility can cater for any specific colour requirement.

